

ROTO CONE VACUUM DRYER

The improved technology in Tapasya's Roto Cone Vacuum Dryer integrates drying operation under vacuum. It facilitates enhanced drying efficiency for heat labile or heat sensitive products, low temperature operation and economy of process by total solvent recovery. It also helps cGMP - based working by achieving optimum dust control, while offering the advantage of efficient charging and discharging of material. The dryer is also available with an optional thermal medium system and is ideal for meeting the drying needs across various industries such as API, chemical, Food etc.



Features:

- Total cGMP finish construction
- All contact parts in SS 316L
- Jacket fabrication to accept varied heating sources
- Optimum and continuous vacuum maintenance during processing
- Working cone totally leak proof during operation
- Easy loading with quick discharge
- Uniform Material shuffling over the heated contact surface of cone
- Suitable size condensers and receivers for solvent collection
- Preventive controls on Energy heads to maintain operational efficiency
- Mechanical seals for vacuum and heating sides
- Vacuum / Gravity & Bin loading system for Minimal Material handling
- Can be offered in Nickel, Hastalloy, Titanium and Tantalum
- All rotating parts are provided with - SS Guards for Operator Safety
- Interlocking with Drive through Proximity Switch



RCVD with Chopper Integration



SS316L Sintered Filter Vacuum Nossel



Hermetically Sealed Top Lid

Benefits For You:

- Enhanced drying operation
- Total solvent recovery
- Economy of process
- cGMP compliant process
- Varied drying applications



Control Parameter Pharma cGMP Application

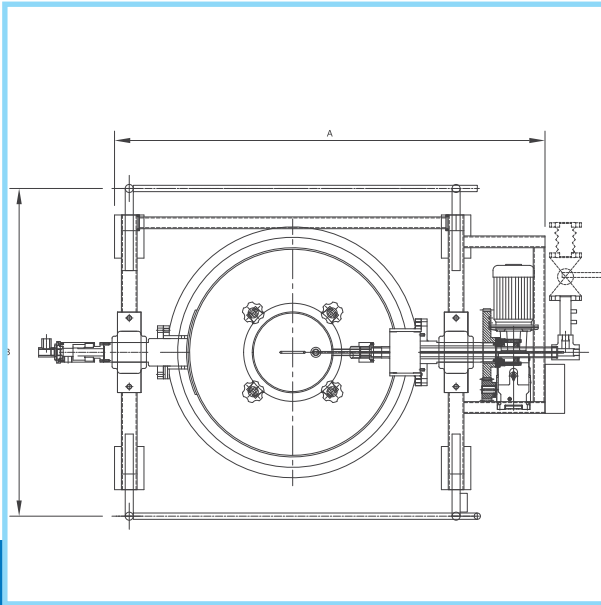

Plan view

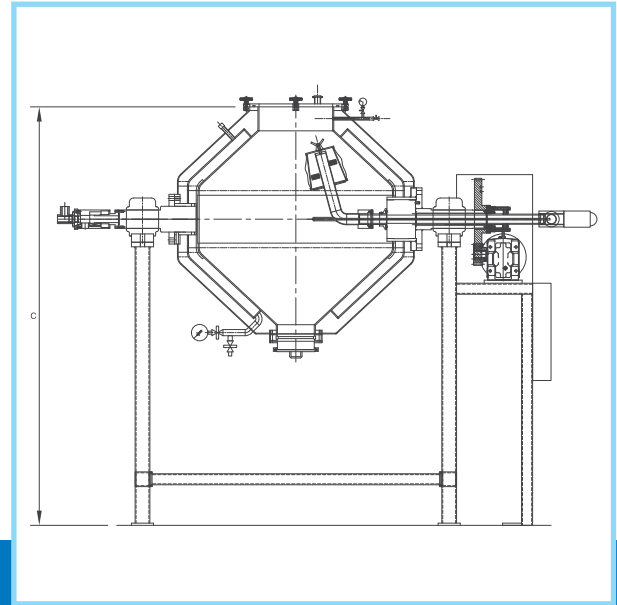

Elevation view

Technical Specifications:

MODEL	GROSS CAPACITY (in Liters)	WORKING CAPACITY (in Liters)	OVERALL DIMENSIONS (in mm)			MOTOR HP	APPROX. WEIGHT (in kg)
			L	B	H		
TAP-RCVD-100	100	60	1100	1200	1600	3	800
TAP-RCVD-300	300	180	1400	1400	2100	3	1600
TAP-RCVD-500	500	300	2200	1600	2300	5	2000
TAP-RCVD-1000	1000	600	2600	1800	2600	7.5	2500
TAP-RCVD-2000	2000	1200	3000	2000	3400	10	3500
TAP-RCVD-5000	5000	3000	4200	2200	3700	15	5500
TAP-RCVD-10000	10000	6000	4500	2600	4200	25	6500

Customised sizes available on request

Roto Cone Vacuum Dryer used in Industries:

- Pharmaceutical
- Nutraceutical
- Food
- Chemical
- Cosmetics