

# IN-PROCESS BATCH CONTAINER (IBC)

Tapasya offers a variety of containers for your 'In-Process' material handling and storage needs. Each of these containers can be custom designed to meet your specifications of volume / weight to be contained within and transfer of material.

Tapasya offers Circular Conical IBC, Circular Drums & Conta Bin / Blending IBC of varying capacities.



## Features:

### Circular Conical IBC:

- Hermetically sealed intermediate Product Container
- Ergonomically designed handles and 60o angle of response for easy of material flow and handling
- P.U. Wheels and an inside / outside surface finish of <math><0.3 \text{ Ra}</math>

### Circular Drums:

- Perfect dimensions for loading / unloading operations for to & from blenders
- Built-in level-sensing port
- P.U. Wheels and an inside / outside surface finish of <math><0.3 \text{ Ra}</math>

### Conta Bin / Blending IBC:

- Square Hermetically sealed bins with loose detachable trolley
- Ideal for size 50L to 800L
- P.U. Wheels and an inside / outside surface finish of <math><0.3 \text{ Ra}</math>



Drum Bin



Toolless Assembly Sanitary Valve

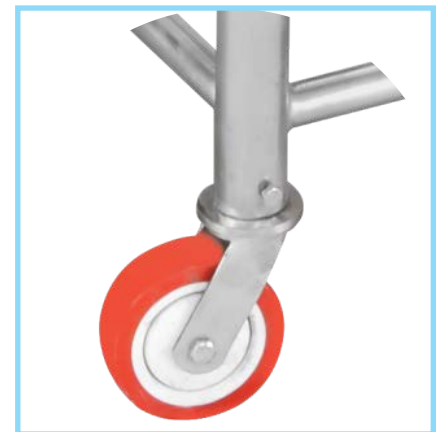

PU Wheel

## Benefits For You:

- Convenience in Production units
- Durable & Safe Storage Option
- Easy handling & Movement of Raw materials and In-Process Materials



Circular Conical IBC



Conta Bin / Blending IBC

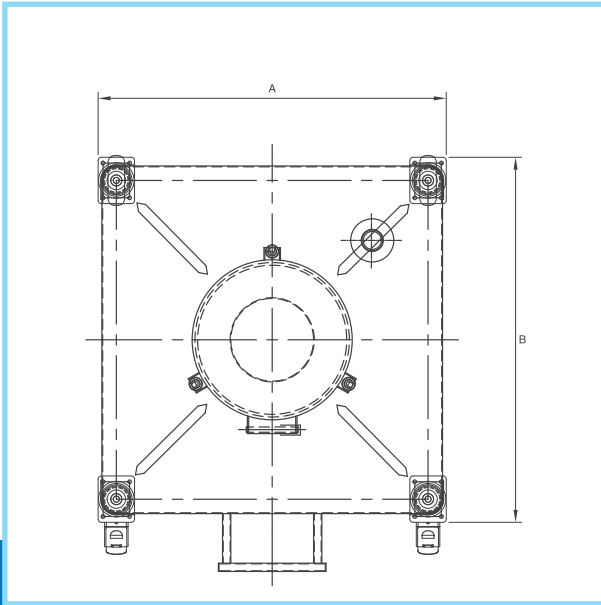

Plan view

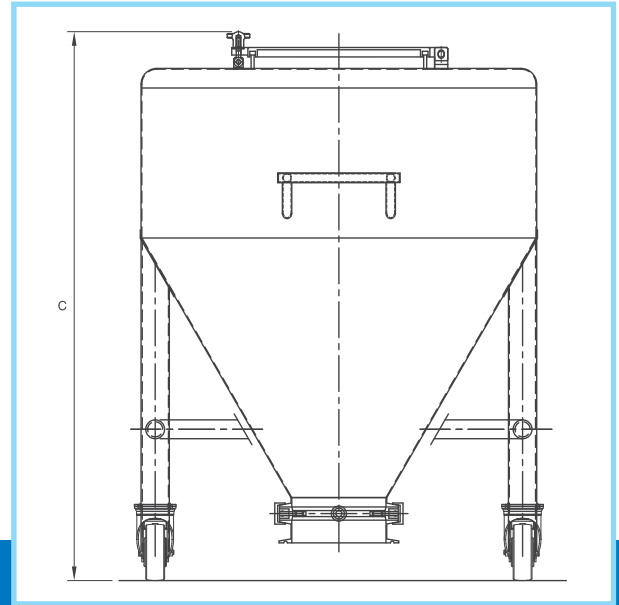

Elevation view

### Technical Specifications:

MODEL	GROSS CAPACITY (in Liters)	WORKING CAPACITY (in Liters)	OVERALL DIMENSIONS (in mm)			APPROX. WEIGHT (in kg)
			L	B	H	
TAP-IBC-100	100	80	900	700	900	100
TAP-IBC-200	200	160	950	50	1050	140
TAP-IBC-300	300	240	1000	1000	1200	170
TAP-IBC-500	500	400	1100	1050	1400	200
TAP-IBC-1000	1000	800	1200	1150	1650	250
TAP-IBC-1500	1500	1200	1450	1400	1700	300

Customised sizes available on request

### In-Process Batch Container used in Industries:

- Pharmaceutical
- Nutraceutical
- Food
- Chemical
- Cosmetics