

PALLET WEIGHING TRUCK

Tapasya's Mobile Weighing System, a compact and portable system, is a superior option to the typical fixed weighing platforms in the production area. Widely used in the Pharmaceutical, Nutraceutical and other allied industries, this system eliminates the need for to & fro movement of ingredients and finished products for merely weighing purposes as it enables online weighing facility.

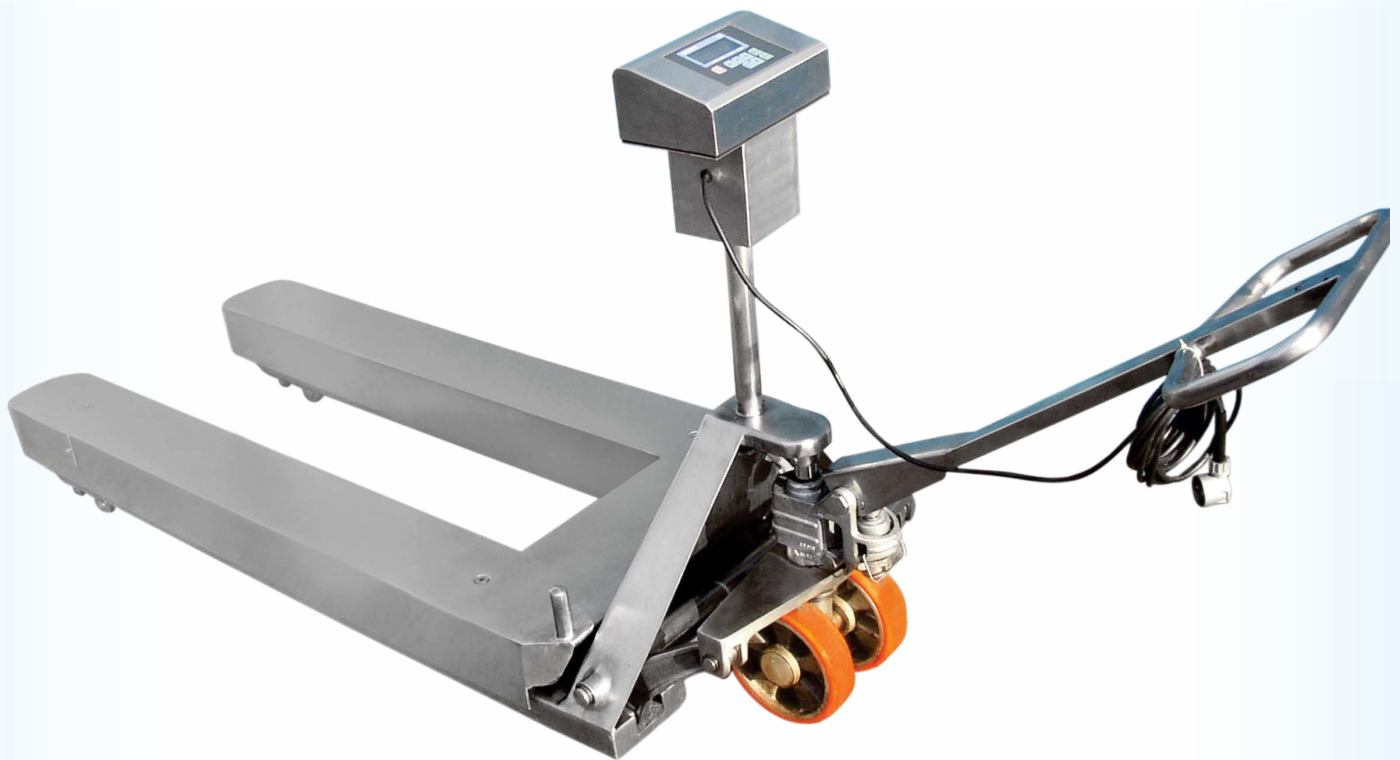

Features:

- Top Quality
- Stable Design
- High load bearing capacity
- New Rapid action lift
- Battery operated
- FLP design for explosive areas
- Constructed using SS 304 making it corrosion resistant

Benefits For You:

- Accurate Online Weighing
- Compact & Portable
- Convenient in Production units
- Durable & Safe Weighing Option



High Load Bearing Capacity PU Wheel



Weighing Display

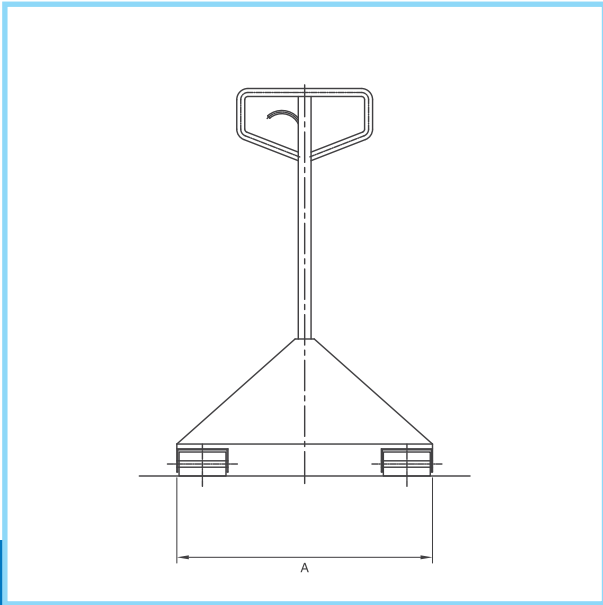

Front view

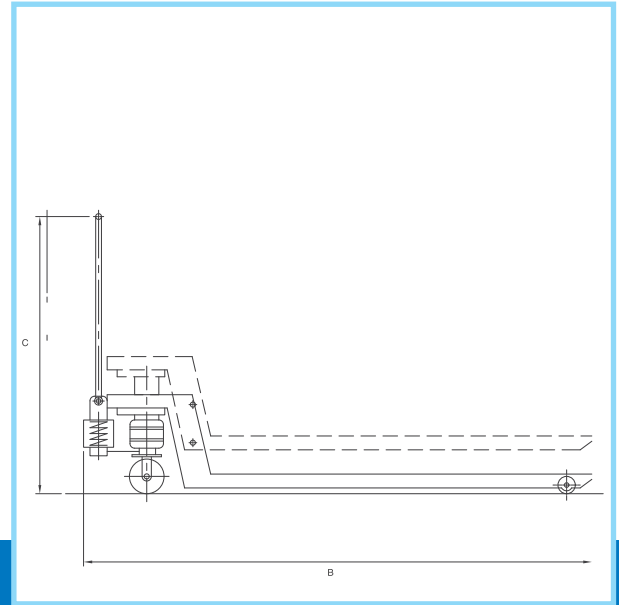

Side view

Technical Specifications:

MODEL	GROSS CAPACITY (in kg)	WORKING CAPACITY (in kg)	OVERALL DIMENSIONS (in mm)			MOTOR HP	APPROX. WEIGHT (in kg)
			L	B	H		
TAP-PWT-1000	1000	1000	800	2200	1200		100
TAP-PWT-2000	2000	2000	800	2200	1200		120
TAP-PWT-3000	3000	3000	1000	2200	1200		150
TAP-PWT-4000	4000	4000	1000	2200	1200		180

Pallet Weighing Truck used in Industries:

- Pharmaceutical
- Nutraceutical
- Food
- Chemical
- Cosmetics