

TIPPER

Tapasya's Tipper, a Hydraulically or mechanically operated equipment is used for lifting and tipping granules from the FBE Bowl to granulating equipment and through it to a BIN or an IPC container. The Tipper provides a dust free operation and eliminates tedious scooping or manual handling and is fabricated with high quality SS to impart a cGMP finish.

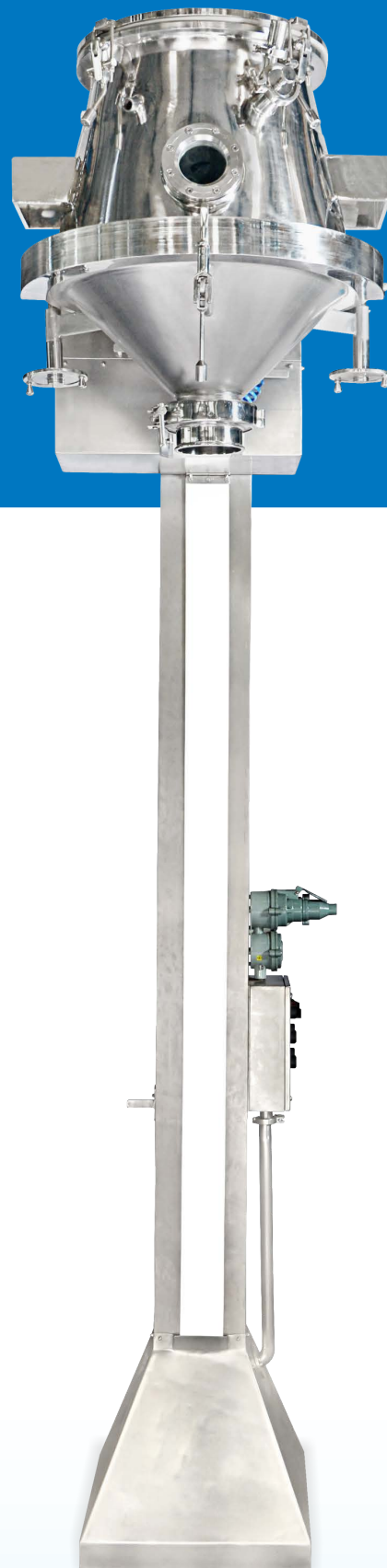

Features:

- High Quality SS for lift ypkce & discharge cone clamps
- Water tight Control cabinet with hydraulic power pack & electric controls
- Stable Design conforming to cGMP/cGEP Standards
- Hydraulic Cylinder with 3 stage Fail safe seals designed for an operating pressure of 100 BAR
- Solid Machined trolley made out of 30 MM Machined Frame
- 2 no.s 8 MM Ø SS 304 Wire ropes instead of chain
- Lift Lock for safety
- Imported Mono Block Power Pack
- Control Cabling and rigid piping included
- CE Certified meeting 19 EN specifications
- Built-in provision for the Vibratory Sifter/ Mill to be electrically connected
- Hydraulic Tilting arrangement for maintenance free operation
- Limit switches for up & down movement
- Limit switches for stopping the cone in 0 degree & 180 degree
- M.C.B. and overload relays for electrical faults
- Pilot operated Hose Burst Valve on the hydraulic cylinder for hydraulic safety
- Single cone for 2 sizes of FBE Bowl with adaptor
- Timer control for discharge valve
- Mechanical & Pneumatic locking for Safety



180° Tilting

Benefits For You:

- Dust-free transfer operations
- Eliminates manual handling & tedious scooping
- Low maintenance
- Designed to European Safety Standards & cGMP standards
- Variety of Optional features available including
- Free standing unit
- Hydraulic / Mechanical design
- Adjustable stop
- Additional lift column height
- Double Column for heavier loads
- Hydraulic arrangement for tilting
- 180° SWIVEL column
- Pneumatically actuated valve
- Single cone for 2 sizes of FBE Bowl with adaptor



Material Handling without Human Interference

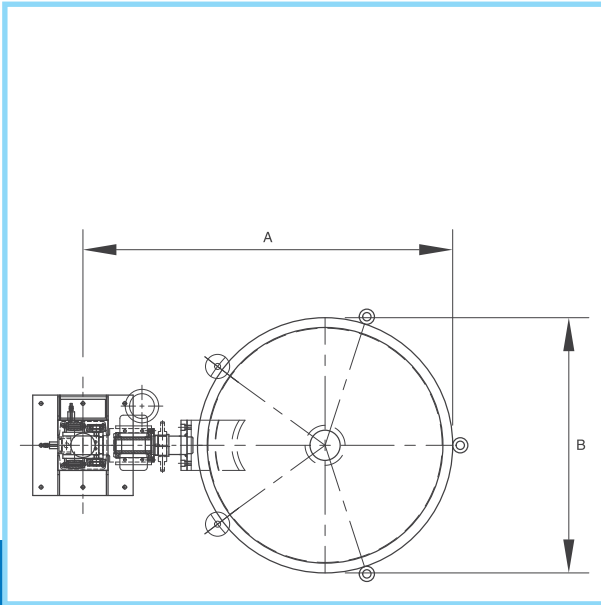

Plan view

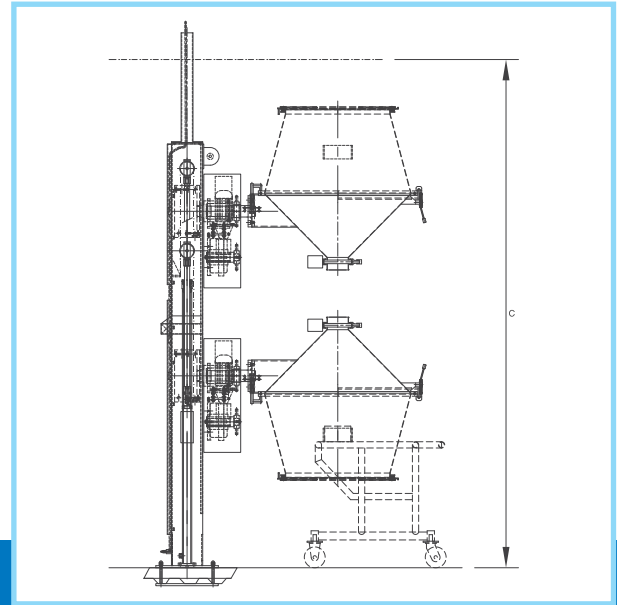

Elevation view

Technical Specifications:

MODEL	GROSS CAPACITY (in Liters)	WORKING CAPACITY (in Liters)	OVERALL DIMENSIONS (in mm)			MOTOR HP	APPROX. WEIGHT (in kg)
			L	B	H		
TAP-LTD-150	150	120	1020	1870	4000	3.5	600
TAP-LTD-250	250	200	1290	2370	4000	3.5	700
TAP-LTD-500	500	400	1330	2370	4000	4.5	800
TAP-LTD-750	750	600	1760	2520	4400	4.5	1000
TAP-LTD-1000	1000	800	1790	2800	4400	6.5	1100
TAP-LTD-1400	1400	1120	1420	2320	4500	6.5	1300
TAP-LTD-1700	1700	1360	3730	1720	4500	6.5	1500

Customised sizes available on request

Tipper used in Industries:

- Pharmaceutical
- Nutraceutical
- Food
- Chemical
- Cosmetics