

MULTI MILL

Tapasya's Multi-mill is ideal for high speed Granulating, Pulverising, Mixing, Shredding and Chopping of a wide range of wet and dry materials without special attachments. This machine utilises the principle of variable force swing hammer blades, having both knife and impact edges, rotating with a carefully selected screen to control size reduction. The product enjoys wide applications in the Chemicals, Pharmaceuticals, dyestuff, colours, ceramics, food products, cosmetics, pesticides, fertilizers, plastics, spices, bakeries, resins, insecticide and other industries.



Features:

- Efficient Dust contained Multi mill
- Machine Portable on Castor wheels
- High output with Process uniformity
- All contact parts are in SS 316L
- Direction of the Blade rotation can be changed using a Reversing switch for Hammer or Knife operation for various product type
- Multiple combinations of Screens / Speeds / Number of Blades available for every Product type
- Higher Screen opening area for Higher Throughput
- Easy Dismantling and Cleaning of all Components reducing Production Downtime and increasing Productivity
- Additional perforated screen at the bottom of pulverising chamber ensuring Higher Fineness and Controlled Size of Granules
- Built in Variable Frequency Drive for multiple speeds

Benefits For You:

- High speed operations
- Minimal material handling
- Dust-free operations
- Easy to handle
- Higher throughput
- Easy maintenance



Knife and Hammer Blade Design



Multi Mill Mobile Model

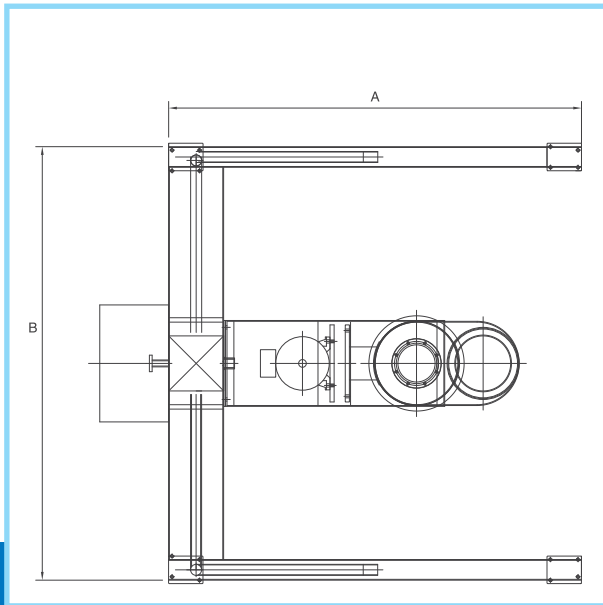

Plan view

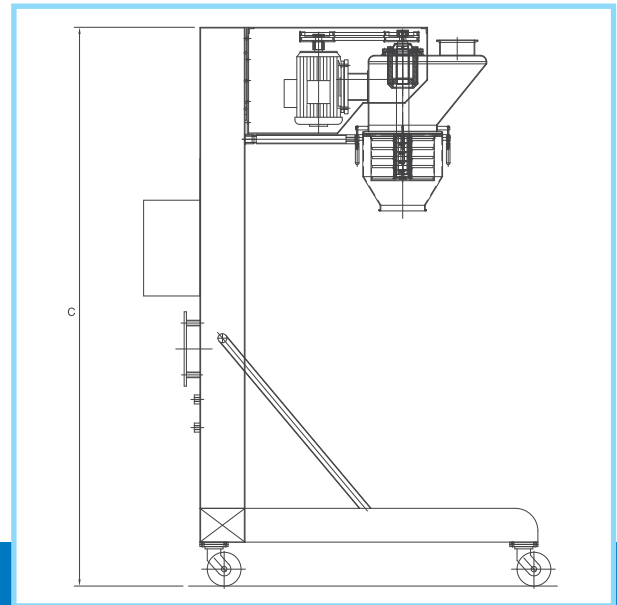

Elevation view

Technical Specifications:

MODEL	GROSS CAPACITY (in Kg)	WORKING CAPACITY (in Kg)	OVERALL DIMENSIONS (in mm)			MOTOR HP	APPROX. WEIGHT (in kg)
			L	B	H		
TAP-MM-250	250	250	1500	1400	2200	3	600
TAP-MM-500	500	500	1500	1400	2400	5	800

Customised sizes available on request
 Laboratory model design available

Multi Mill used in Industries:

- Pharmaceutical
- Nutraceutical