

OSCILLATING GRANULATOR

Tapasya's Oscillating Granulator is ideal for meeting the multiple needs of Dry Granulation, Wet Granulation, Screening, Crushing, Breaking lumps, etc for the Pharmaceutical and Nutraceutical industry. The oscillating motion of the rotor with uniform speed and force applied to the material, improves the granulating process and enhances the compressibility of the product.



Features:

- Oscillating rotor with back and forth motion for even distribution of material
- SS construction (AISI 316 / 316L)
- Inside polished Ra = 0.8 micron, outside ground (grain 220)
- Maintenance free design, GMP execution
- Multiple varieties of sieves, fine sieves & perforated plates available to suit all your needs
- Range 0.5 mm to 10 mm
- Robust, Simple & Compact Design
- Easy Installation in Production Line
- Low noise level as per international norms
- Easy for Cleaning



cGMP Construction in SS316L

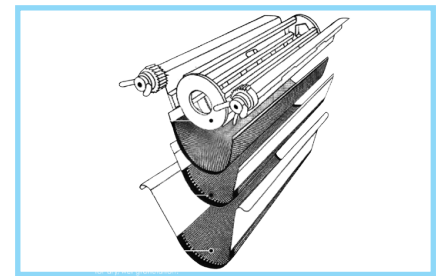

Perforated Sieve for Dry / Wet Granulation

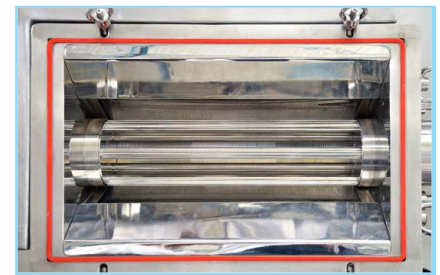

Nibbling Blades for Gentle Granulation

Benefits For You:

- High output with uniform sized granules and less fines
- Easy maintenance



Automated Control System

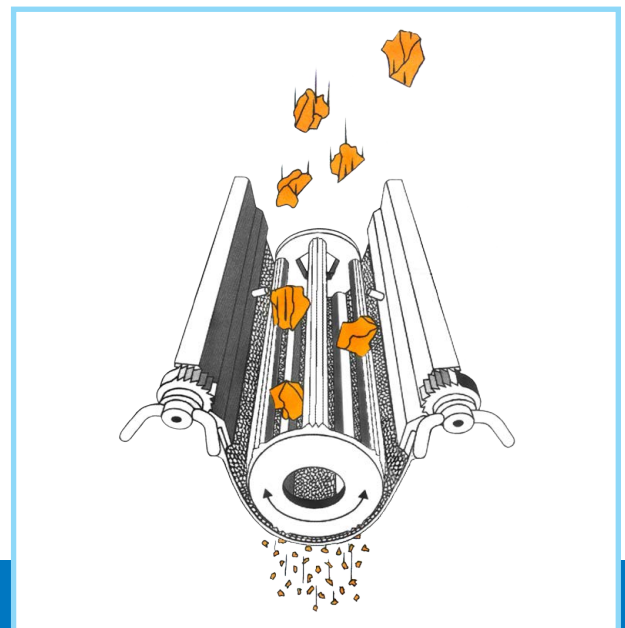

Precision Design for Uniform Granules and Less Fines

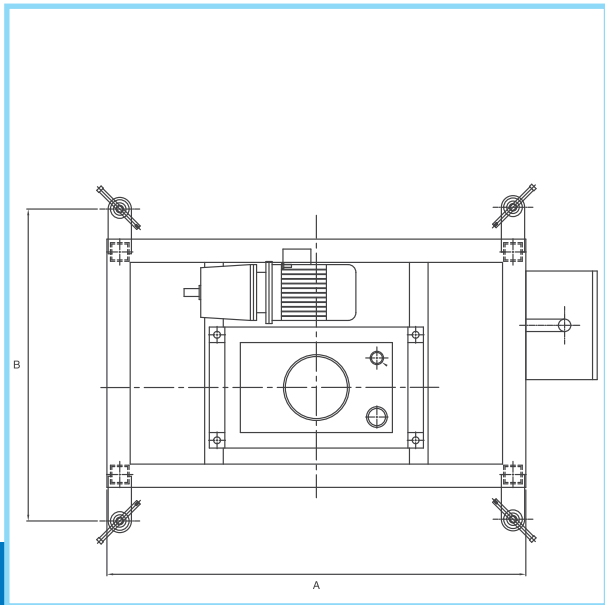

Plan view

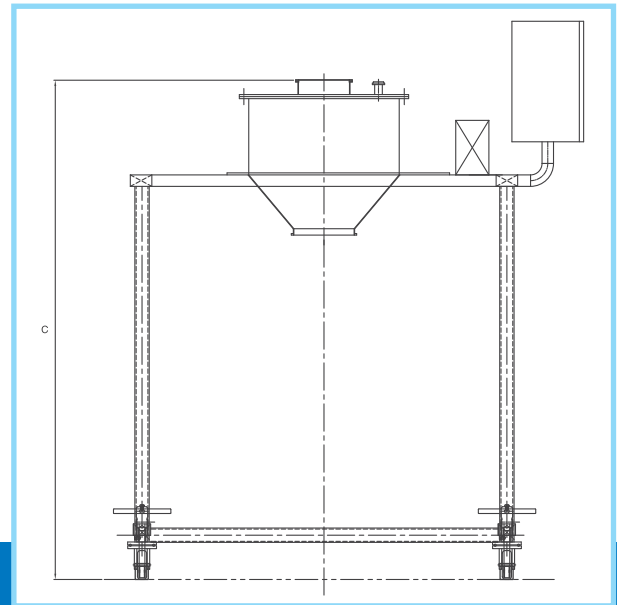

Elevation view

Technical Specifications:

MODEL	GROSS CAPACITY (in Kg)	WORKING CAPACITY (in Kg)	OVERALL DIMENSIONS (in mm)			MOTOR HP	APPROX. WEIGHT (in kg)
			L	B	H		
TAP-OG-250	250	250	1250	1600	1600	3	600
TAP-OG-500	500	500	1250	1600	1800	5	900

Customised sizes available on request

Oscillating Granulator used in Industries:

- Pharmaceutical
- Nutraceutical