

TAP CONE MILL

Tapasya's Tap Cone Mill is used for High Speed Shredding, Sizing, and Grinding of Powders, Granules, Tablets and a wide range of wet and dry materials, without special attachments. As compared to the four common principles of size reduction i.e. cutting, attrition, impact and pressure, which often do not produce controlled size reduction, this machine utilises the principle of Centrifugal Shearing force. It has wide applications in the Pharmaceutical and Neutraceutical industry for shredding of rejected tablets, Dry Milling, Wet Milling, Shredding of oversized material (De lumping), etc.



Features:

- Material of construction SS 316L
- Compact size online model also available
- Imported Laser Driller Mesh for Dry application
- Safety Standards with no outside cables
- Vacuum Loading option
- Bin charging Loading system option
- Dust free closed system for charging and discharging of powders or granules
- Easy to clean
- Minimum maintenance
- Different profile of blade and sieve available



Sanitary Process Chamber Design



Special Design Sieve for Efficient Milling

Benefits For You:

- High speed shredding, sizing & grinding
- High safety standards
- Dust-free closed system
- Minimal maintenance
- Varied applications



Cover Hopper



Toolless Assembly

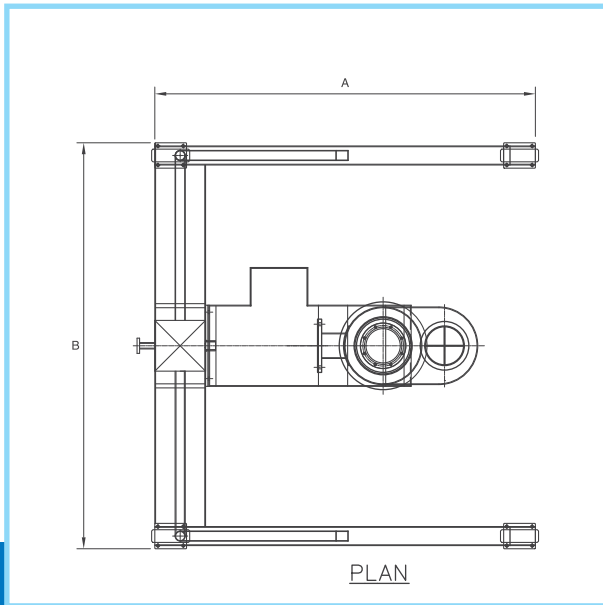

Plan view

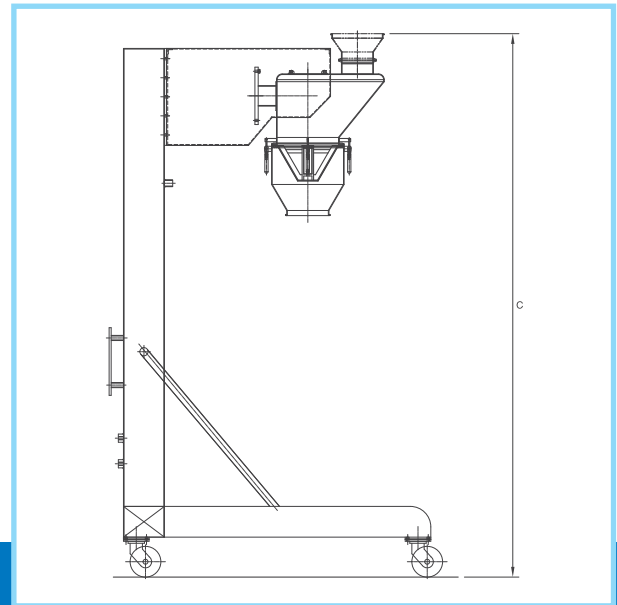

Elevation view

Technical Specifications:

MODEL	GROSS CAPACITY (in Kg)	WORKING CAPACITY (in Kg)	OVERALL DIMENSIONS (in mm)			MOTOR HP	APPROX. WEIGHT (in kg)
			L	B	H		
TAP-TCM-50	50	50	1050	1500	1900	1	400
TAP-TCM-250	250	250	1500	1400	2200	3	600
TAP-TCM-500	500	500	1500	1700	2400	5	800

Customised sizes available on request
 10 bar compliant equipment available
 Laboratory model design available

Tap Cone Mill used in Industries:

- Pharmaceutical
- Nutraceutical